

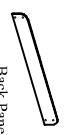

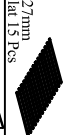









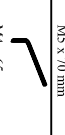
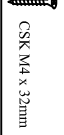

A		2 pcs
B		1 pc
C		1 pc
D		1 pc
E		1 pc
F		1 pc
G		1 pc
H		2 pcs
I		1 pc
J		4 pcs
Packing Hardware		
1		1 pc
2		1 pc
3		72 pcs
4		4 pcs
5		4 pcs
6		4 pcs
7		6 pcs
8		24 pcs
9		16 pcs

Step 1: Attach side rail (D) & (E) to arm (A) by pushing the bracket down to fit it.

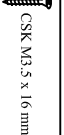
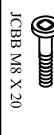

Step 2: Attach the Back Panel (B) to the arm (A) as shown.

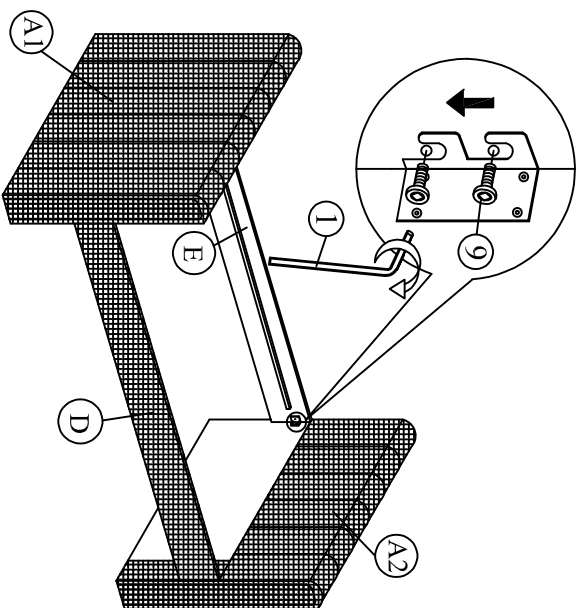
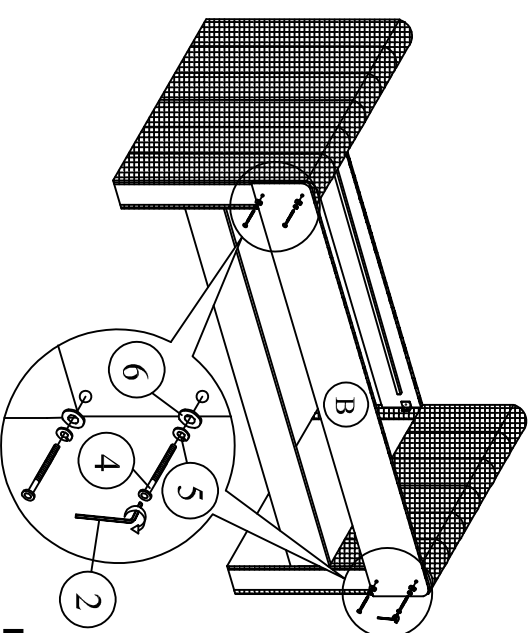

BACK VIEW

Step 3: Tighten the 4 Corner with Allen Key (1). Install the slats to side rail. Tighten the slats with CSK screw (3). The distance of the slats should be sufficient to obtain desirable bed stability.

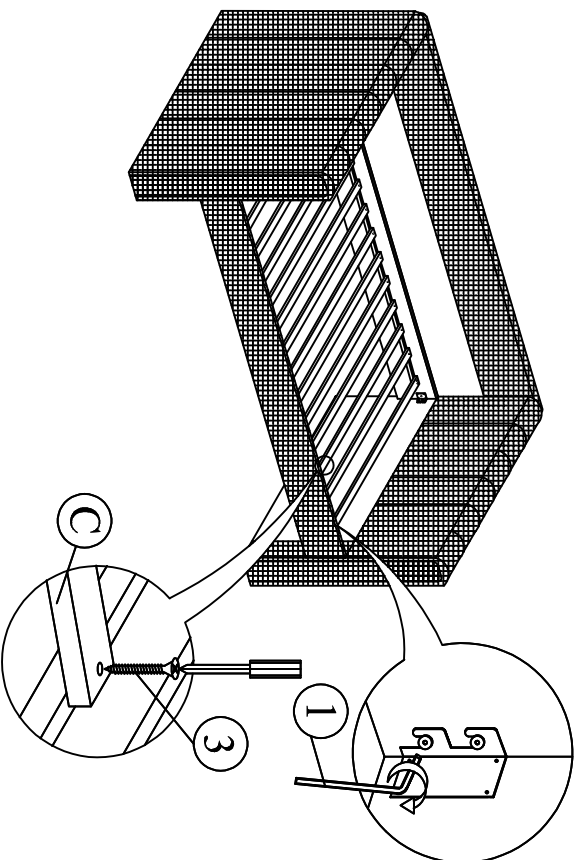

Step 4: Attach trundle side panel (H) and trundle front panel (F) to trundle back panel (G) by pushing the bracket down to fit it.

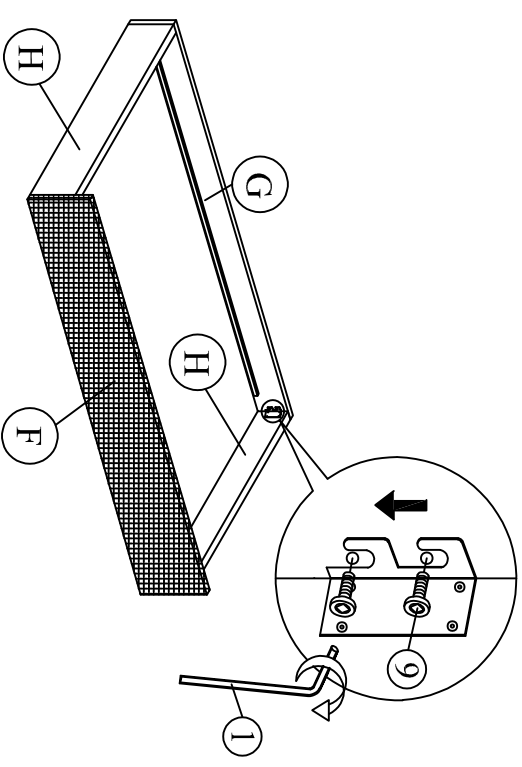

Step 5: Affix the roller (7) to the slat (1) follow the marking on the slat (1).

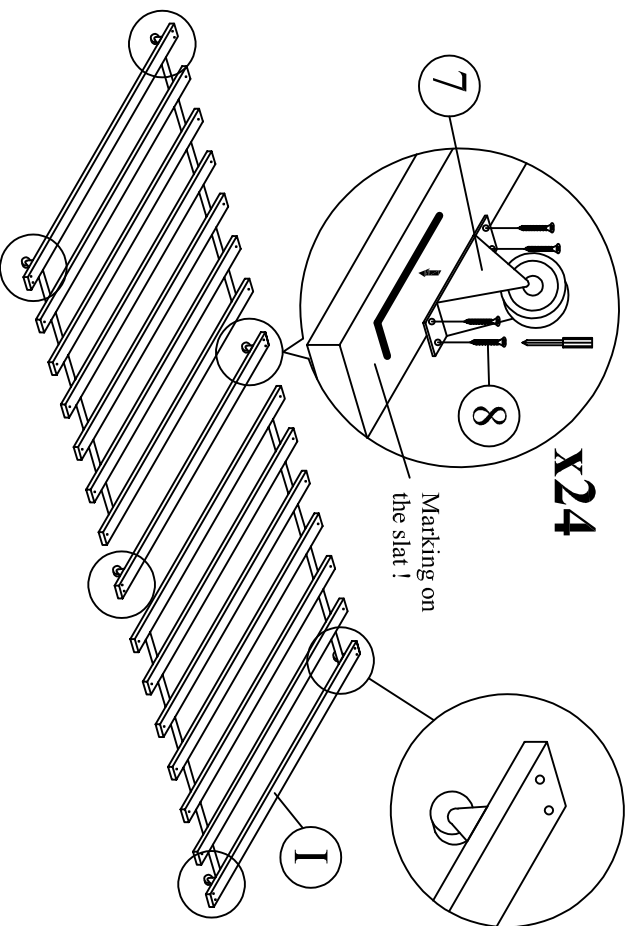

Step 6: Place the wooden blocks (J) at the corner of the trundle and fix the slat (1) to the trundle at (F) & (G).

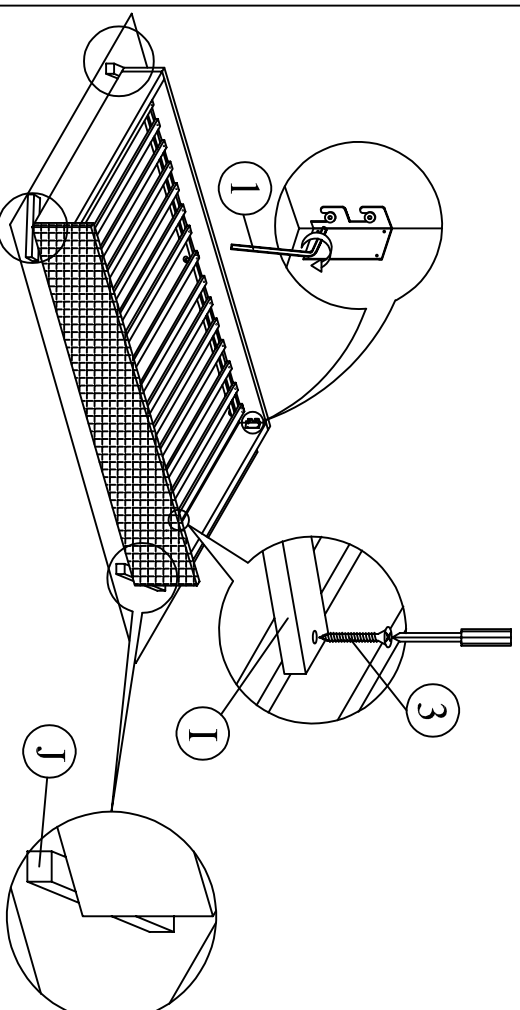

Step 7 : Assembly is complete.

